

1 Features

Appears as USB Virtual Com Port
Multiple configuration options
Weighs 0.345oz (9.8g)
Small form factor (2.0"L 1.0"W 0.5"H)
Windows Visual Basic Sample
Application Available

SSP-x (Accelerometer)

3-axis accelerometer
Single gain mode set to +/-16g
15-bit resolution
User selectable sample rate of 12, 25,
50, 100, and 200 Hertz

SSP-b (Barometer)

30000 – 110,000 Pa pressure range
Absolute accuracy of 10 Pa, typ
User defined sample period of 2Hz to
once per 32 seconds

2 Applications

The SSP is applicable to:

SSP-x (Accelerometer)
real time motion capture
tilt monitoring
vibration monitoring

SSP-b (Barometer)

GPS navigation enhancement
Weather monitoring
Temperature Reading

3 Description

The Serial Sensor Package (SSP) allows for quick and easy monitoring of acceleration or barometric pressure data using a simple virtual com port interface.



Figure 1: SSP

3.1 Operating Instructions

The SSP uses the Silicon Labs CP210 USB serial interface chip to establish a connection via the USB port. The serial port is configured for 115200 baud, 8bit, no parity, single stop bit, and no flow control. Once a serial connection is established, the SSP will begin to stream data at the default sample rate of 50Hz (SSP-x) or 1Hz (SSP-b).

Sending a “?” to the SSP will return a list of available commands (see below). System status messages are appended with the “;” character. The receiving software application should include a filter to separate the messages from the data stream.

3.1.1 SSP Command List

The SSP will recognize the following commands from the host and respond with a message appended with “;”.

Table 3.1: SSP Command Set

Comm and Character	Description	SSP Response
'c'	configuration	SSP-x: system speed and gain SSP-b: sample period
's'	status	SSP-x: sample rate and deadband (deadband not an implemented) SSP-b: sample period
'v'	version information	ID, firmware, firmware date, sensor part#
'd/D'	turn On/Off data stream	'd' starts data stream, 'D' pauses data (clock continues when data is paused)
'+/-'	double/half sample rate	'+' doubles current sample rate (sample period for SSP-b) '-' reduces current sample rate by half (sample period for SSP-b)
'm/M'	micro-resolution On/Off	'm' activates micro-resolution timing such that time stamps include 0.1ms precision, “M” deactivates (not implemented on SSP-b)
'x'	reset the device	Restarts the clock and begins data streaming

3.1.2 SSP-x Accelerometer Sample Output

The accelerometer output can be read from left to right as: time, Ax, Ay, Az.

Time – elapsed seconds from last device reset.

Ax, Ay, Az – raw sensor data expressed as “counts”. Divide the value by 1024 to determine “g”.

```
61863.317, 2, -136, 1032
61863.397, 3, -136, 1033
61863.478, 4, -134, 1033
61863.559, 2, -135, 1033
61863.639, 4, -136, 1032
```

The default sample rate is 50Hz. The sample rate is changed by sending a “+” or “-” command, which doubles or halves the rate, respectively. Therefore, the available sample rates are 12, 25, 50, 100, and 200 Hz.

3.1.3 SSP-b Barometer Sample Output

The barometer output can be read from left to right as: time, P, T.

Time – elapsed seconds from last device reset.

P – pressure expressed in pascals

T – temperature in °C * 10 (ie, 262 = 26.2°C)

```
61.932080, 101741, 262
62.924272, 101727, 262
63.914512, 101733, 262
64.906704, 101732, 262
65.896944, 101739, 262
```

The default sample rate is 1 Hz, or one sample per second. Sending a “+” or “-” will double or half the current sample period. The available sample periods are 0.50, 1, 2, 4, 8, 16, and 32 seconds.

3.1.4 Linux Operation

1. Open a command terminal. Type `sudo tail -f /var/log/messages`.

2. Plug the SSP into the USB port. Look for the following line:

```
Nov 6 09:45:50 localhost kernel: [175430.497314] usb 1-1.2.1.2: cp210x converter now attached to ttyUSB1
```

3. The above messages states that the device is attached to ttyUSB1. Press control-c to exit the /var/messages.

4. Setup the terminal by typing `stty -F /dev/ttyUSB1 -opost -onlcr -isig -icanon -iexten -echok -echo -echoctl -ixon -crtcts ignbrk -icrnl`.

5. In the terminal type `cat /dev/ttyUSB1`. The data from the SSP will display to the terminal. Enter `cat /dev/ttyUSB1 | test.csv` to stream data to a file named test.csv.

3.1.5 Windows Operation

1. Download and install a serial terminal program, such as Hyperterminal, TeraTerm, or Realterm. The following example uses TermTerm.
2. Download and install the CP210x USB drivers from Silicon Labs.
<http://www.silabs.com/products/mcu/pages/usbtouartbridgevcpdrivers.aspx>.
3. Plug the SSP into a USB port. Open your serial terminal program of choice and configure the appropriate port to a baud rate of 115200, 8N1, and no flow control. The port number can be found using the Windows Device Manager under “Ports (COM & LPT)”.

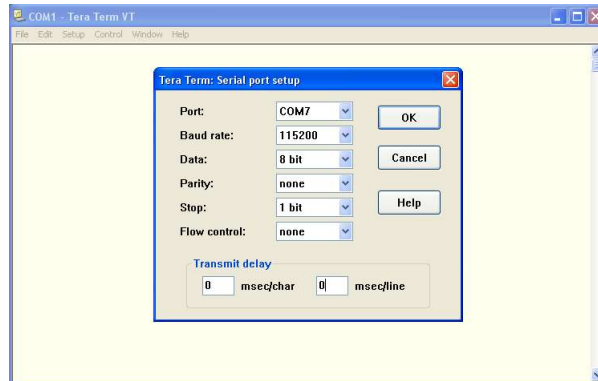

Figure 2: Serial Port Configuration

4. Activate the connection and data from the SSP is displayed by the terminal program.

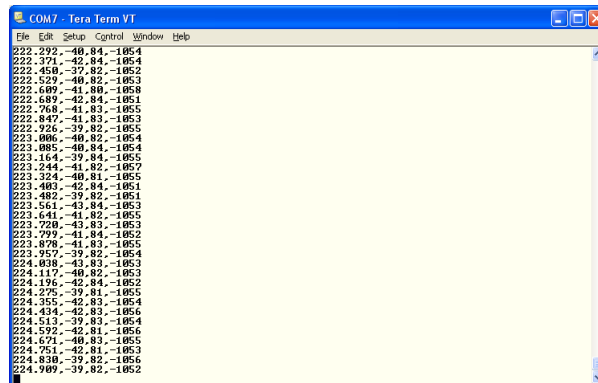

Figure 3: SSP-x Example Output

An example Visual Basic program is available at <http://www.gcdataconcepts.com/ssp.html>

The Visual Basic program shows how to access the serial data interface and plot the data.

Windows will support multiple SSP devices attached simultaneously but the SSP devices must have unique serial numbers. By default, the SSP devices do not have a serial number assigned. A serial number can be assigned to the SSP using the Silicon Labs utility:

<http://www.silabs.com/Support%20Documents/Software/an721sw.zip>

3.1.6 Labview Operation

There is a very good tutorial on setting up the serial port in labview at <http://www.youtube.com/watch?v=RM8a66g2eGo>

3.1.7 Matlab Operation

An example of setting up the serial port in matlab can be found at:

http://www.mathworks.com/help/matlab/matlab_external/getting-started-with-serial-i-o.html

3.2 Electrical

3.2.1 SSP-x Accelerometer Sensor

The SSP-x uses the Analog Devices ADXL345 3-axis digital accelerometer sensor. The sensor is oversampled 4 times and averaged to produce the 15-bit resolution output.

Table 3.2: SSP-x Accelerometer Sensor Characteristics

Parameter	Condition	Min	Typical	Max	Units
Acceleration range			±16.0		g
Resolution			1024		count/g
Linearity	X, Y, Z axis		±1		%FS
Zero-g Offset Level Accuracy	X, Y axis	-150		+150	mg
	Z axis	-250		+250	mg
Inter-Axis Alignment Error			±0.1		Degrees
Cross-Axis Sensitivity			±1		%

3.2.2 SSP-b Barometric Pressure Sensor

The SSP-b uses the Bosch Sensortec BMP-085 high precision pressure sensor. The temperature compensation algorithm is implemented in the SSP-b microprocessor.

Table 3.3: SSP-b Barometric Pressure Sensor Characteristics

Parameter	Condition	Min	Typical	Max	Units
Operating temperature	Operational			+85	C
	Full Accuracy			+65	°C
Absolute accuracy pressure $V_{DD}=3.3\text{ V}$	70000 - 110000 Pa (0 to +65 °C)	-250	±100	+250	Pa
	30000 - 70000 Pa (0 to +65°C)	-300	±100	+300	Pa
	30000 - 110000 Pa (-20 to 0 °C)	-400	±150	+400	Pa
Resolution of output data	Pressure				Pa
	Temperature				°C
Relative accuracy pressure	70000 – 110000 Pa (@ 25°C)		±20.0		Pa
	0 – 65°C (@ p constant)		±50.0		Pa
Absolute accuracy temperature	@ +25°C	-1.5	0.5	+1.5	°C
	0 - 65°C	-2.0	±1.0	+2.0	°C

3.3 Mechanical

The SSP electronics are enclosed in a two part plastic enclosure. The SSP weighs 0.345oz (9.8g) and is just 2.0"L 1.0"W 0.5"H. USB connection is made using a female micro-B connector.

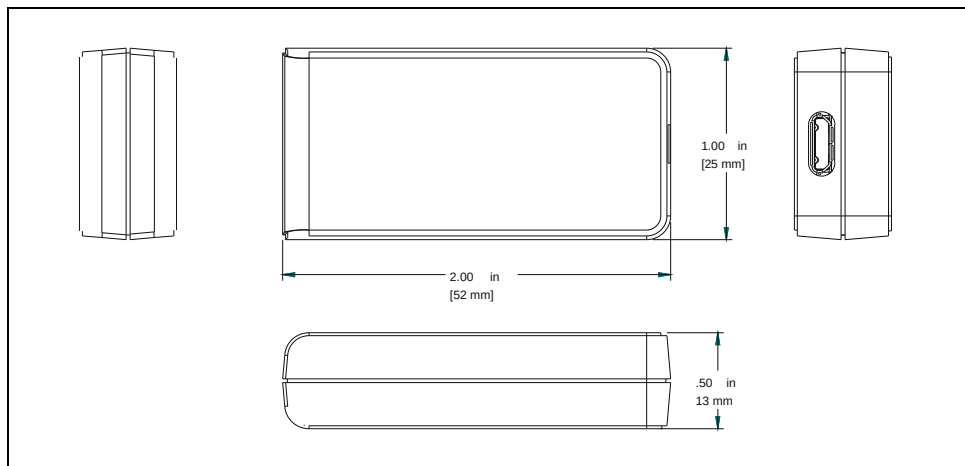

Figure 4: SSP Dimensions