

1 Features

- 3-axis accelerometer
- $\pm 2g$ or $\pm 6g$ range in each axis
- 12-bit and 16-bit resolution modes
- User selectable sample rates of 20, 40, 80, 160, and 320 Hz
- Internal Li-Poly battery charges via USB
- User selectable deadband and trigger
- Accurate time stamped data using Real Time Clock (RTC) with power back-up
- Data recorded to a 1GB microSD card
- Easily readable comma separated text data files
- Data transfer compatible with Windows or Linux via Universal Serial Bus (USB) interface (no special software)
- System appears as USB Mass Storage Device to Windows and Linux OS's.
- Weighs 0.63oz (18g)

2 Applications

The X6-2mini is applicable to:

- Monitoring human motor activity, or actigraphy, such as exercise intensity or sleeping disorders.
- Educational purposes

3 Description

The USB Accelerometer X6-2mini functions as the X6-2 product but without the on/off feature or status indicators. The X6-2mini is designed to continually collect data once removed from a USB port. Acceleration is collected in X, Y, and Z axes and stored at a user selectable rate of up to 320Hz. The X6-2mini mounts as a standard mass storage device, which facilitates easy access to the comma delimited text data files and user setup files. The internal 250mAh lithium-polymer battery provides approximately 18 hours of operation at 80 Hz and charges using the USB power.

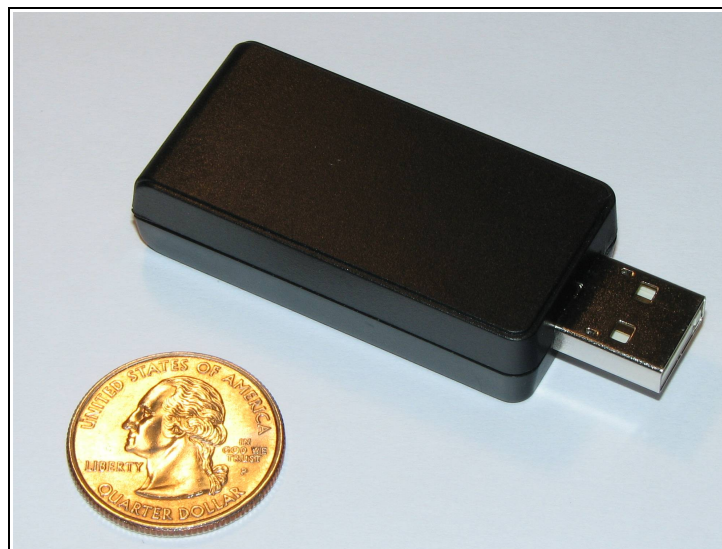

Figure 1: X6-2mini

3.1 Operating Instructions

The X6-2mini is a simple, economical solution to capture continuous motion data and quickly deliver the information for analysis. The following instructions outline the steps to begin using the X6-2mini. Configuration settings and mounting methods will depend on the particular application.

- Step 1: Ensure the internal lithium-polymer battery is fully charged by plugging the X6-2mini into a computer USB port. Approximately 90 minutes will fully charge a depleted battery.
- Step 2: Configure the X6-2mini by editing the appropriate tags in the config.txt file. Choose faster sample rates to capture rapidly changing events. Use high gain 16-bit modes to monitor very small motion or vibration. Refer to section 3.2.3 for a complete list of configuration options.
- Step 3: If necessary, initialize the RTC clock by creating a time.txt file (see section 3.2.5). Setting the RTC ensures that recorded data can be correlated to absolute time.
- Step 4: Unplug the X6-2mini from the USB port and the device will boot. If the time.txt file is present, the RTC is initialized with the time written in the file. The X6-2mini continues to collect data until the device is returned to a USB port or the battery is depleted.
- Step 5: To stop recording, return the X6-2mini to a USB port. Data files are present in the file directory named “GCDC”. Data recording is restarted by removing the device from the USB port.

NOTE: To turn off the X6-2mini, delete or comment out the “rebootondisconnect” line in the configuration file. Remove the device from the USB port and the new option is loaded for the next reboot event. Plug and unplug the device once more and the X6-2mini will turn off completely. Replace the “rebootondisconnect” line in the configuration file and the device will return to the normal operating sequence.

3.2 Electrical

3.2.1 Sensor

Table 1: Accelerometer Sensor Characteristics

Parameter	Condition	Min	Typical	Max	Units
Acceleration range	High Gain	±1.8	±2.0		g
	Low Gain	±5.6	±6.0		g
12-bit Resolution	High Gain (±2g)		0.001		g/count
	Low Gain (±6g)		0.003		g/count
16-bit Resolution	High Gain (±2g)		0.00006		g/count
	Low Gain (±6g)		0.00020		g/count
Linearity	X, Y axis		±2		%FS
	Z axis		±3		%FS
Zero-g Offset Level Accuracy	High Gain (±2g) X, Y axis	-0.002		0.002	g
	High Gain (±2g) Z axis	-0.004		0.004	g
	Low Gain (±6g) X, Y axis	-0.004		0.004	g
	Low Gain (±6g) Z axis	-0.006		0.006	g

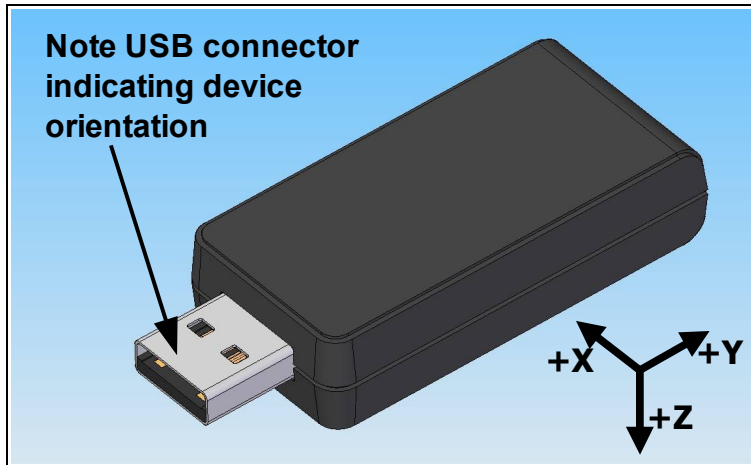

Figure 2: X6-2mini Accelerometer Sensor Orientation

3.2.2 Battery

The X6-2mini is powered by a internal, hardwired 250mAh lithium-polymer rechargeable battery. The internal battery management system recharges the battery when the X6-2mini is plugged into a USB port. A depleted battery is fully charged in about 90 minutes. The battery provides approximately 18 hours of operation sampling at 80Hz with the deadband set to zero (maximum data recording capability). Greater operating times are achieved with slower sample rates and appropriate use of the deadband limit. The battery is not used when the system is connected to a computer USB port. A 5v

supply via the USB connector provides extended operation of the device independent of the internal battery. Common USB power adapters or USB battery packs for consumer electronics can provide the required 5v supply. See section 3.2.3.14 for more details.

3.2.3 System Configuration Options

The X6-2mini is configured using a set of tags and settings stored in a text file named “config.txt”, which is located in the root directory of the microSD card. The system reads the configuration file at boot time. Table 2 lists the configuration file tags. A tag is followed by an equal sign (“=”) and an applicable tag setting. A line finishes with a newline character or carriage return character. Tags are not case sensitive. Tab and space characters are ignored. Lines starting with a semicolon (“;”) are treated as comments and ignored by the system. The system will use the default settings listed in Table 2 if the config.txt file is not found.

Table 2: Configuration File Tags and Descriptions

Tag	Valid Settings	Default	Description
16bitres	-	Off	Sets device to record data at 16-bit resolution
deadband	An integer between 0 and 32767	0	Sets the deadband to a range expressed in “counts”. A new sample is recorded if any sensor axis exceeds the previous recorded reading by the deadband value
deadbandtimeout	An integer between 0 and 65535	3	Specifies the period in seconds when a sample is recorded regardless of the deadband setting. This feature ensures periodic data is recorded during very long periods of inactivity.
dwel	An integer between 0 and 65535	1	The number of samples recorded after a deadband threshold triggered event
gain	“high” and “low”	low	High gain sets the system to record +/-2g, low gain records +/-6g
hpf	0, 24, 25, 26, 27	Holds previous setting	Implements a high-pass filter, 0 turns the filter off
microres	-	Off	The presence of this tag sets the device to record time stamps with 0.1ms effective precision.
rebootondisconnect	-	off on disconnect	The presence of this tag causes the system to start recording after disconnect from a USB port.
samplesperfile	An integer greater than 0	28896	The number of lines of data per data file before a new file is created
samplerate	10, 20, 40, 80, 160, 320	40	Sets the rate at which data is collected and recorded to the microSD card.
starttime and stoptime	See section 3.2.3.11	-	Defines when to start and stop recording
stoponusb	-	Off	Stops data logging if 5v USB power is present (see section 3.2.3.12)
statusindicators	“Normal”, “High”, “Off”	Normal	LED status indicators can be activated with normal brightness (Normal), activated with high brightness (High), or completely deactivated (Off).
timeoutonusb	-	Off	Stops USB if no host communications detected (see section 3.2.3.14)

3.2.3.1 16bitres

Add “16bitres” on a single line in the configuration file and the X6-2mini records acceleration data at 16-bit resolution. The default mode is 12-bit resolution. Section 3.2.4 describes how to convert the 12-bit or 16-bit data format into units of g (standard acceleration of gravity).

3.2.3.2 deadband

“deadband” defines the minimum difference between recorded sensor readings. A new sample from the accelerometer sensor must exceed the previous recorded reading before the microcontroller records the data. The deadband setting is expressed in "counts" units and is applied to the output of each axis. Table 3 lists the equations necessary to convert a desired g threshold to deadband counts. The deadband value can be set to an integer between 0 and 32767. The deadband function is an effective way to reduce the amount of data collected and extend the system battery life. The deadband functions as a event threshold limit when used in conjunction with the “dwell” feature.

Table 3: Deadband Calculation

AD Resolution	Gain Setting	Deadband Counts
12-bit	Low	340×g
	High	1024×g
16-bit	Low	5440×g
	High	16384×g

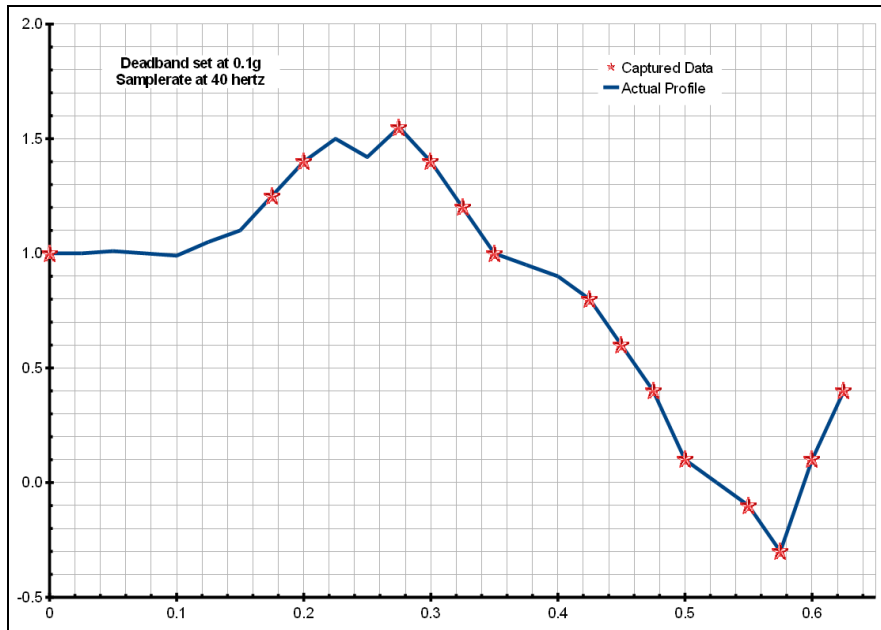

Figure 3: Graphical Illustration of the Deadband Feature

3.2.3.3 deadbandtimeout

“deadbandtimeout” defines the period in seconds when a sample is recorded by the device regardless of the deadband setting. This feature ensures periodic data is recorded during extended periods of inactivity. A valid setting for the deadbandtimeout is an integer between 0 and 65535.

3.2.3.4 dwell

The “dwell” tag defines the number of consecutive samples recorded at the set sample rate after a deadband threshold event. The deadband threshold event occurs when a sensor reading exceeds the last recorded value by the deadband setting. A valid dwell setting is an integer between 0 and 65535.

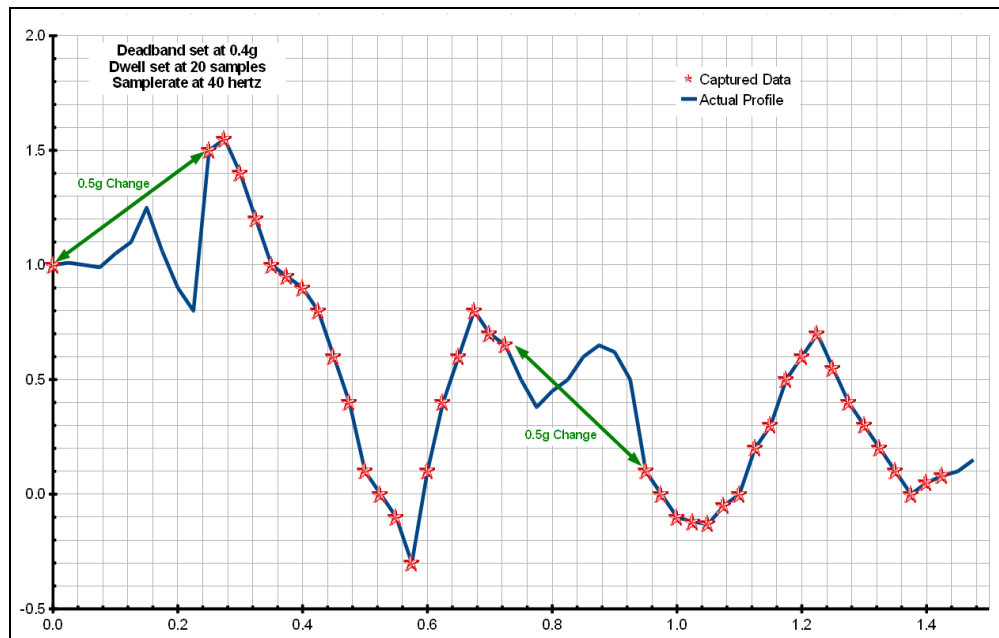

Figure 4: Graphical Illustration of the Dwell Feature

3.2.3.5 gain

“gain” defines the sensor scale. “high” sets the system to record at $\pm 2g$. “low” sets the system to record at $\pm 6g$.

3.2.3.6 hpf

A high-pass filter is implemented using the “hpf” tag with one of five possible settings. The -3dB lower cutoff frequency is defined in Hertz by the HPF tag and the sample rate, as listed in Table 4.

Table 4: HPF -3dB Cutoff Frequencies (Hz)

Tag Setting	Sample Rate (Hz)					
	10	20	40	80	160	320
hpf = 0	Turns high pass filter off					
hpf = 24	0.0031	0.0062	0.0124	0.0248	0.0497	0.0994
hpf = 25	0.0016	0.0031	0.0062	0.0124	0.0248	0.0497
hpf = 26	0.0008	0.0016	0.0031	0.0062	0.0124	0.0248
hpf = 27	0.0004	0.0008	0.0016	0.0031	0.0062	0.0124

3.2.3.7 microres

The “microres” option sets the device to record time stamps with 0.1ms precision. In micro-resolution mode, the time stamps are recorded as XX.YYYYZZ where XX are seconds, YYYY are 0.1 milliseconds, and ZZ are spurious digits that should be ignored. The micro-resolution option should be implemented at sample rates of 80 hertz or greater to provide the best timing precision. The power saving features of the X6-2mini are disabled in micro-resolution mode and battery life is shortened accordingly.

3.2.3.8 rebootondisconnect

Initiating and terminating the data recording process is handled by the “rebootondisconnect” feature. Data recording is automatically started upon disconnect from a computer USB port if the tag word “rebootondisconnect” is included in the configuration file. Data recording is terminated when the device is returned to a host USB port. Note that the system must first be turned on and the configuration file read before the rebootondisconnect option is implemented by the system. Subsequent disconnects will then cause a reboot and immediate data recording.

Although the X6-2mini does not include an on/off button, a button connection point is included on the printed circuit board. The addition of a momentary on/off button is supplied by the end-user.

3.2.3.9 samplesperfile

“samplesperfile” defines the number of data lines each file can have before a new file is created. This tag controls the size of the data files into easily manageable lengths for later processing. This setting is loaded as a signed 32-bit integer, which can translate into very large data files. The user should exercise caution before setting large files and test the end-user application for data limitations.

3.2.3.10 samplerate

The “samplerate” tag defines the interval that data is recorded in Hertz, or samples per second. Valid sample rate settings are 10, 20, 40, 80, 160 and 320 Hz. At 80 Hz or greater, the configuration file should also include the “microres” tag to provide the best timing precision (see section 3.2.3.7).

3.2.3.11 starttime and stoptime

The X6-2mini starts and stops data recording based on the times defined using the “starttime” and “stoptime” tags. The times must be in “MM HH” 24-hr format with the two entries separated by a space. Entries marked with “*” operate as a wild card. The stop time is 5 seconds after the start time unless defined otherwise by the stoptime tag. Example timing configurations:

Example 1: Start recording at 12:30pm and stop recording at 6:00pm.

```
starttime = 30 12  
stoptime = 00 18
```

Example 2: Start recording at the beginning of every hour and stop recording at the 45 minutes later.

```
starttime = 00 *  
stoptime = 45 *
```

3.2.3.12 stoponvusb

The “stoponvusb” tag stops data logging operations when a 5v supply is detected on the USB connector. By default, the device switches power from the internal battery to the USB 5v and continues to log data.

3.2.3.13 statusindicators

The brightness intensity of the LED status indicators is defined using the “statusindicators” tag and valid settings of “normal”, “high”, and “off”. Note that the indicator LEDs are populated on the printed circuit board but are hidden by the opaque plastic enclosure. There is a blue status LED, a memory access red LED, and a red battery charge indicator LED.

3.2.3.14 timeoutonusb

The “timeoutonusb” tag returns the microprocessor to normal operating speed if no USB communications are detected within 7 seconds after connection to a USB port. This reduces the power requirements when operated from an external 5v USB supply. By default, the microprocessor continues at high-speed mode waiting for USB communications. Utilize the timeoutonusb feature when operating the device from an external 5v USB battery pack.

3.2.3.15 Example Configuration Files

Example A) The following configuration records data constantly at 20 hertz in low gain mode (+/-6g). The device will boot and begin logging data once removed from a computer USB port. Each data file is 30,000 lines long or about 25 minutes.

```
; example X6-2mini config file
; set range to +/-6g
gain = low
; set to record constantly at 20hz
samplerate = 20
deadband = 0
; set file length
samplesperfile = 30000
; make device start upon USB disconnect
rebootondisconnect
```

Figure 5: Configuration File Example A

Example B) The device is most sensitive at 16-bit high gain. Micro-resolution is activated for maximum timing precision. Setting the deadband to 0 counts causes the device to record constantly at the set sample rate of 80 Hz.

```
; example X6-2mini config file
; set range to +/-2g, 16bit
gain = high
16bitres
; set to 80hz
; turn on microresolution
samplerate = 80
microres
; record constantly
deadband = 0
; set file length
samplesperfile = 50000
; make device start upon USB disconnect
rebootondisconnect
```

Figure 6: Configuration File Example B

Example C) If motion exceeds 32 counts (0.1g at low gain), the device captures continuous data 40 times a second for 2 seconds or until the change in acceleration falls below 0.1g. A sample is recorded every 5 minutes. The stoponvusb and timeoutonusb options stop data logging and expedite charging while the device is connected to a USB 5v power adapter.

```
; example X6-2mini config file
; set range to +/-6g
gain = high
; set to 40hz
samplerate = 40
; set threshold > 0.1g
; record 2 seconds of data
deadband = 32
dwell = 80
; force a write every 5 minutes
deadbandtimeout = 300
; set file length
samplesperfile = 30000
; recharge batt with 5v USB adapter
; do not record data during charge
stoponvusb
timeoutonusb
; make device start upon USB disconnect
rebootondisconnect
```

Figure 7: Configuration File Example C

3.2.4 Data Files

Data is written to files in comma separated text format starting with the file header information and followed by data entries. The header describes the system configuration, firmware version, and the precise time when the file was created. Each header line is preceded with a semicolon (“;”). Table 6 lists the valid header tags. Data entries include a time stamp and the raw accelerometer sensor readings from the X, Y, and Z axes. The time stamp is seconds elapsed from the start time recorded in the header. The raw sensor data format is signed digital “counts”. Table 5 lists the equations for converting the counts data into g (standard acceleration of gravity).

The X6-2mini creates a new data file when the system is booted or when the maximum number of data lines is reached in the previous data file. A system boot condition occurs when the X6-2mini is removed from a computer USB port with the rebootondisconnect feature enabled or when 5v power is restored to the system via the USB connector. Data files are placed in a folder named “GCDC” and are named data-XXX.csv, where XXX is a sequential number starting with 001. The system will create up to 999 files. At the beginning of each file, a header is written describing the system configuration, firmware version, and the precise time when the file was created. Figure 8 represents an example data file.

The last line of the final data file records the reason for the termination, such as “shutdown: switched off”, “shutdown: low battery”, “shutdown: max files exceeded”, “shutdown: vbus disconnect”, or “connected to computer”. The line is designated as a comment with a semicolon (“;”).

```

;Title, http://www.gcdataconcepts.com, X6-2mini
;Version, 1004, Build num, 0x9AA, Build date, 20101022 12:24:18, SN:CCDC22011000617
;Start_time, 2010-11-02, 09:52:44.598
;Switch, Unknown
;Temperature, 34.50, deg C, Vbat, 3672, mv
;Gain, high
;SampleRate, 40,Hz
;Deadband, 0, counts
;DeadbandTimeout, 0,sec
;Headers, time,Ax,Ay,Az
1.599,4,-17,-1017
1.624,4,-17,-1017
1.649,3,-17,-1017
1.674,4,-17,-1017
1.699,4,-16,-1017
1.724,4,-17,-1018
1.750,3,-18,-1018
1.775,3,-18,-1018
1.799,4,-17,-1018
    
```

Figure 8: Example Data File

Table 5: Converting Raw Counts Data to g Units

AD Resolution	Gain Setting	g
12-bit	Low	counts / 340
	High	counts / 1024
16-bit	Low	counts / 5440
	High	counts / 16384

Table 6: Data File Header Tags

Tag	Description
16 bit resolution	Signifies the data format as 16-bit
Deadband	A new sample from the sensor must exceed the last reading by the deadband value
DeadbandTimeout	The period in seconds when a sample is recorded regardless of the deadband setting
Dwell	The number of samples recorded after a threshold event
Gain	“high” or “low” indicating the system gain setting
Headers	The names of each column of data in the file
HPF filter set to:	The high pass filter value
SampleRate	Rate at which data is recorded to the microSD card
Start_Time	The current time when the data file was created
Temperature	Temperature of sensor in °C when data file was created
Title	The name of the USB Accelerometer X6-2mini unit
Vbat	Battery voltage measured at the start time
Version	The version control information of the firmware, including unique serial number

3.2.5 Real Time Clock

A real time clock (RTC) is integrated into the X6-2mini and is used to determine time for each line of data recorded. Initializing the RTC ensures that the start time and individual time stamps can be correlated to an absolute time. An uninitialized or reset RTC defaults to the first day of the year 1900.

The RTC is set using a text file named “time.txt” located in the root directory of the microSD card. The system looks for the time.txt file upon booting. If the file exists, the time stored in the file is loaded to the RTC and the time.txt file is deleted. The time information in the time.txt file must be in the exact “yyyy-MM-dd HH:mm:ss” 24-hour format, occur on the first line, and end with a newline character. The time file method of setting the RTC does not require special communication drivers so it can be implemented using any text editor. Direct initialization of the RTC is possible but requires specific device drivers from Gulf Coast Data Concepts.

The RTC is powered by the lithium-polymer battery or the USB power when available. The RTC also provides the system temperature (°C) recorded to the header of each data file.

3.2.6 Internal Memory

The X6-2mini stores data to an internal 1GB flash memory card and functions as a Mass Storage Device to computer operating systems when transferring data to and from the internal memory. The memory card can be reformatted but must be formatted to FAT16 for proper operation of the X6-2mini. The X6-2mini will create a folder called “GCDC”, if not already present, to place the data files (see section 3.2.4). The “config.txt” and “time.txt” files must occur in the root directory (see section 3.2.3 and section 3.2.5).

3.3 Mechanical

The electronics are enclosed permanently (no user access) in a ABS plastic enclosure. The X6-2mini measures 2.5”x1”x0.5” (63.5x25.4x12.7mm) and weighs 0.63 ounce (18g).

3.3.1 Dimensions

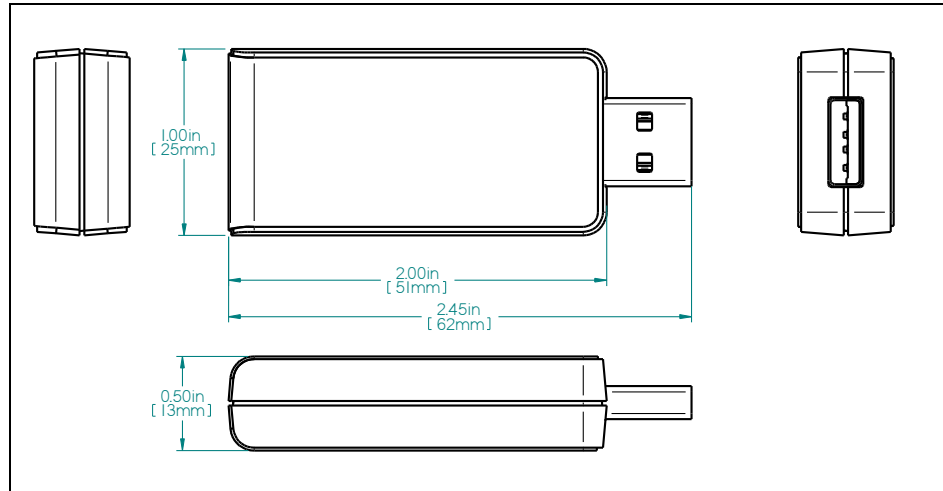

Figure 9: Enclosure Dimensions

4 Software

The USB Accelerometer X6-2mini records data to comma delimited text files and uses text based files for configuration settings. Therefore, no special software is required to utilize the X6-2mini. However, Gulf Coast Data Concepts provides the Java based software program *XLR8R* that allows easy visual presentation of the data, copy-paste export of data segments, as well as configuration file and time file creation utilities. *XLR8R* is included on each X6-2mini unit or can be downloaded from the website at www.gcdataconcepts.com. For data analysis, Gulf Coast Data Concepts recommends using a commercial or open source mathematics package, such as MathCAD, Microsoft Excel, Octave, R, S, or similar applications.